



PRECAST CEMENT PRODUCTS CC

Suppliers Of Quality Splitface, Fairface & Retaining Wall Blocks

55 Stapleton Road, Pinetown, Durban, KZN
 PO Box 4, Sarnia, 3615
 Tel : 031 708 4365/6
 Fax : 031 708 4177

VAT : 4390102608
 CK : 2002/000063/23
 Web : www.precast.co.za
 Email : info@precast.co.za

SOIL RETAINER BLOCKS

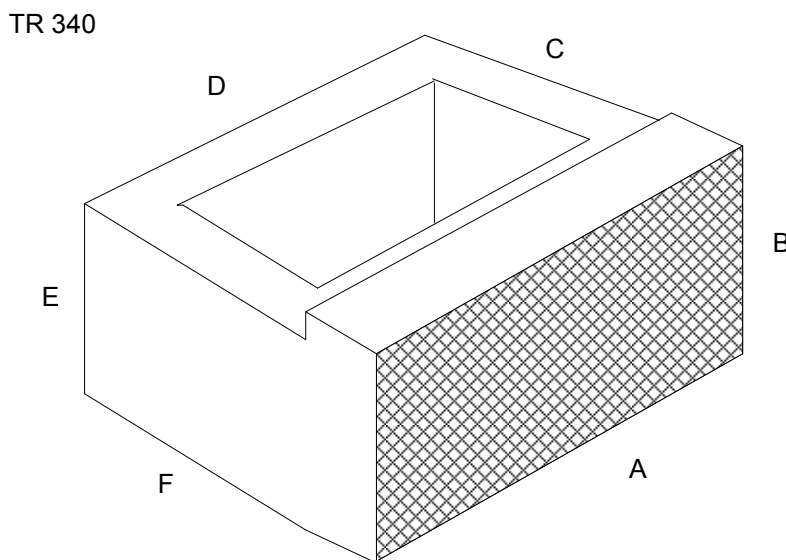
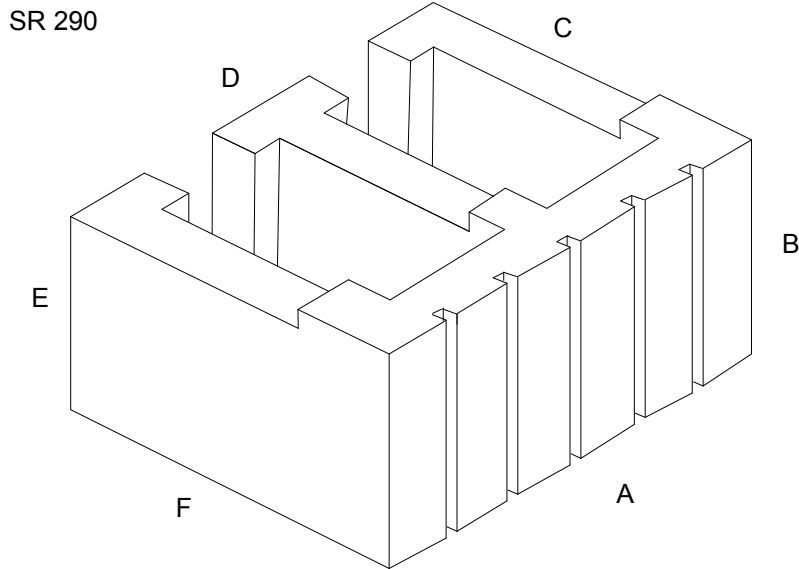

Code Number	A	B	C	D	E	F	Weight (KG)	Number Per m ²	Setback Per meter
SR290	390	205	210	390	190	290	27	12.5	320 = 68°
TR340	390	190	280	340	175	340	25	15	300 = 70°

Suitable for walls with a maximum height of 2.4 metres incl footing



PRECAST CEMENT PRODUCTS cc

Suppliers Of Quality Splitface, Fairface & Retaining Wall Blocks

55 Stapleton Road, Pinetown, Durban, KZN
 PO Box 4, Sarnia, 3615
 Tel : 031 708 4365/6
 Fax : 031 708 4177

VAT : 4390102608
 CK : 2002/000063/23
 Web : www.precast.co.za
 Email : info@precast.co.za

SR290

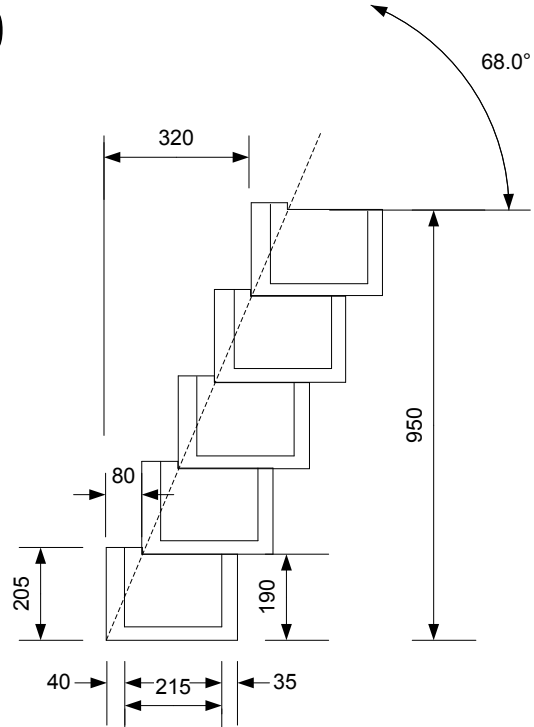
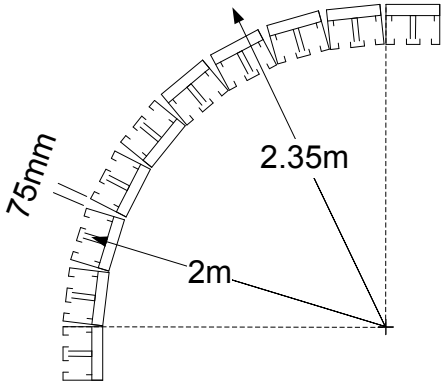

SR290

Corners should be constructed with a radius

EXT curve of 90° will use 8 blocks, 2.35m radius

INT curve of 90° will use 8 blocks, 2m radius

Spacing at front/back of block from edge to edge = 75mm

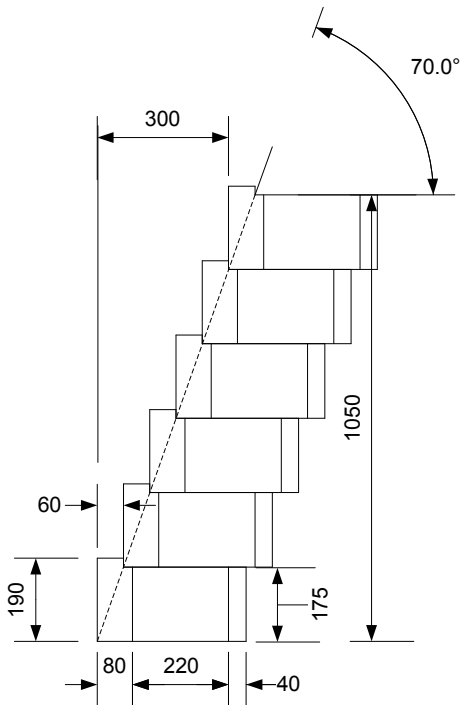

TR340

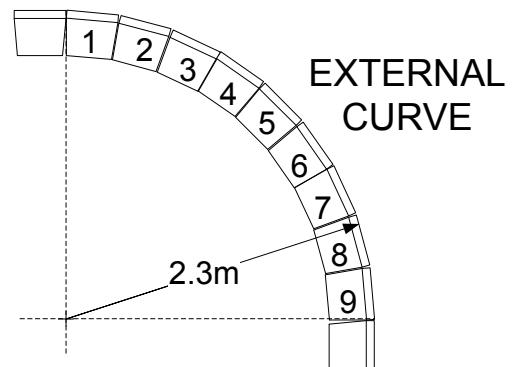
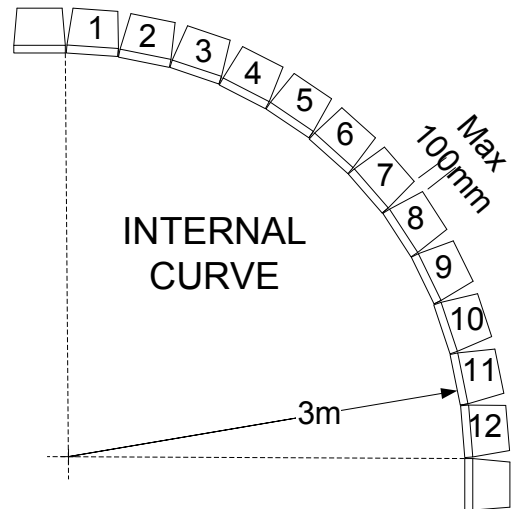

TR340 (Non planter)

Corners must be constructed with a radius

INT 90° 3m radius use 12 blocks

EXT 90° 2.3m radius use 9 blocks

Spacing at back of block = 100mm max